



OPERATION INSTRUCTION
Fillet Weld Gage
Code 4832-1



使用说明书
4832-1 角焊接规

Measuring purpose

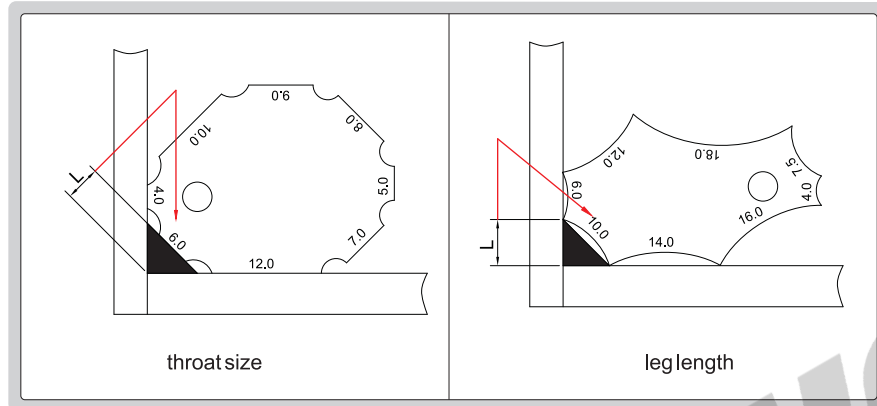

测量方法:

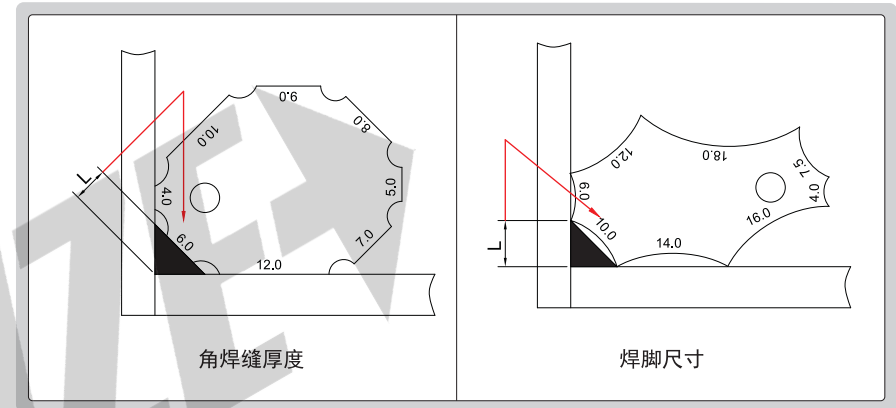

Throat size (mm)	Leg length (mm)	Accuracy
4, 5, 6, 7, 8, 9, 10, 12	4, 6, 7.5, 10, 12, 14, 16, 18	±0.5mm

角焊缝厚度 (mm)	焊脚尺寸 (mm)	精度
4, 5, 6, 7, 8, 9, 10, 12	4, 6, 7.5, 10, 12, 14, 16, 18	±0.5mm

MN-4832-1-C/E

V0

MN-4832-1-C/E

V0